

## 12dBi Directional Patch Indoor/Outdoor Antenna

LevelOne's WAN-1112 12dBi directional antenna is designed for indoor/outdoor wireless connections. With WAN-1112, you can improve signal strength/quality and increase signal coverage for an existing 802.11b/g 2.4GHz wireless local network in a concentrated direction.

This antenna offers high gain in a low profile package. With the directional patch panel design, you can easily install this unit on wall glass surface and in any orientation to maximize wireless coverage. Use of the reverse SMA connector or the included conversion adapter allows you to connect a variety of wireless devices. In order to increase installation flexibility there is no power-source required.

This antenna kit comes with antenna and the 3m UL-168 extension cable and has been tested for interoperating with LevelOne wireless access point, indoor/outdoor building-to-building bridge and other wireless products equipped with reverse SMA male connector and detachable antennas.



**WAN-1112**

### Related Products



**WNC-0301**  
54Mbps Wireless PCI Card



**WAP-0003**  
108Mbps Wireless Access Point



**WAN-1060**  
6dBi Indoor Antenna Kit

## Key Features

- Supports for 802.11b/g 2.4GHz Wireless applications
- Provides stable signals and extends coverage
- Directional operation
- Easy to install on wall surface
- Includes UL-168 3m cable for wireless device with SMA connector

## Radiation Patterns

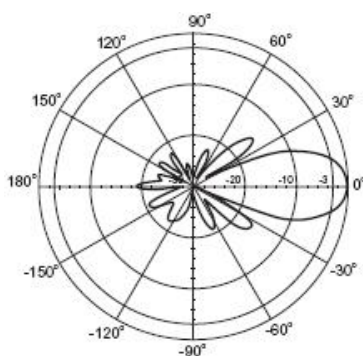

V-Plane Co-polarization Pattern

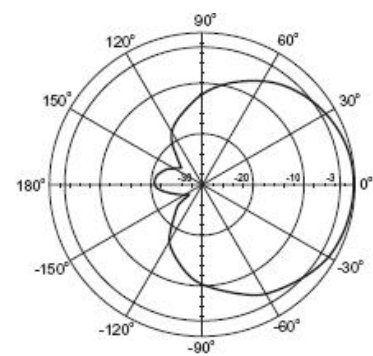

H-Plane Co-polarization Pattern

## Technical Specification

Electrical Specification	
Frequency Band	2400MHz – 2700MHz
Gain	12.0dBi
VSWR	2.0:1 Max
Polarization	Linear, Vertical
HPBW / V	23°
HPBW / H	84°
Front to back ratio	15 dB
Downtilt	0°
Power Handling	20W
Impedance	50 Ohms
Connector	SMA female
Environmental & Mechanical Characteristics	
Survival wind speed	216km/ hr
Temperature	-40°C - +85°C
Humidity	95% @ 25°C
Radome Material	Ivory
Radome material	ABS, UV resistant
Weight	193 gw
Dimension	327mm x 80mm x 22mm

## Product Diagram

Building-to-building  
Short Range Application

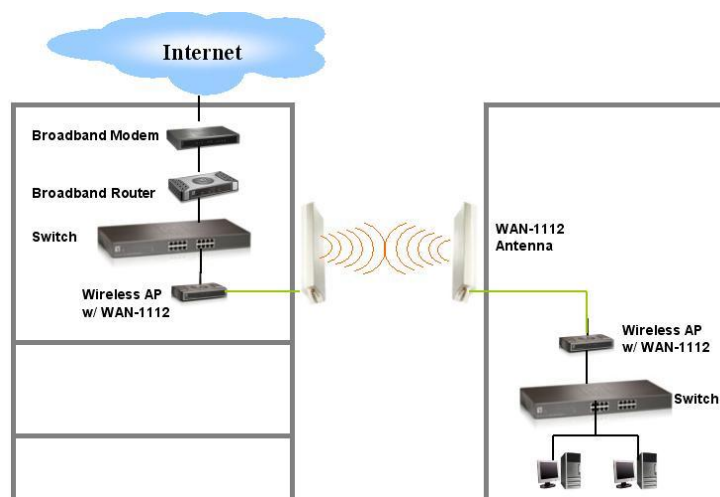

## Ordering Information

- WAN-1112: 12dBi Directional Patch Indoor/Outdoor Antenna  
- 3m UL168 cable; RSMA (female) to RSMA (male)